

HTC-79B/ HTC-79I

HUNT ELECTRONIC CO., LTD.



20M IR CAMERA



FEATURES

- Removable IR Cut filter (ICR), (No focus shift) / option
- No Color Rolling & Low Smear
IR distance: 16 Meter
- Water resistant : IP68
- Up To 540 TVL

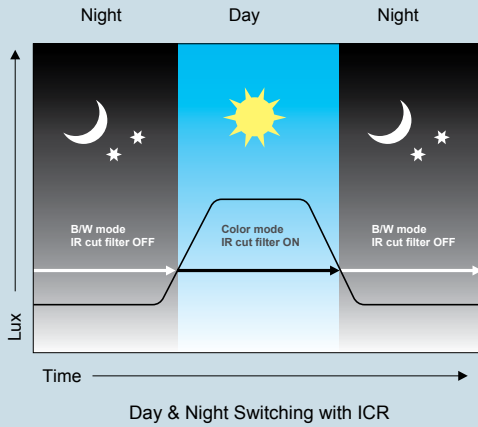

INTERFACE

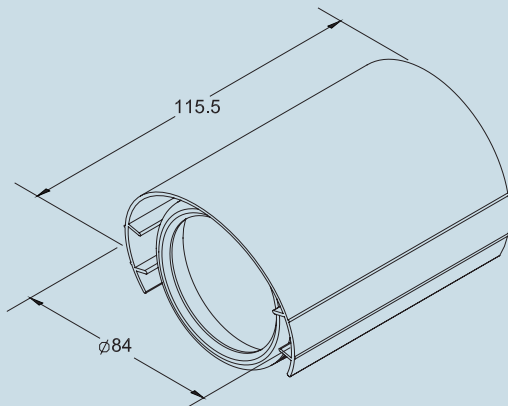

SPECIFICATIONS

ITEM	HTC-79B	HTC-79I
Pick-up Device	1/3" CCD image sensor	
Picture Elements (H*V)	NTSC: 510*492	NTSC: 768*494
	PAL: 500*582 (Med-res.)	PAL: 752*582 (Hi-res.)
H. Sync Frequency	NTSC: 15.734 KHz, PAL:15.625 KHz	
V. Sync. Frequency	NTSC: 59.94 Hz, PAL: 50 Hz	
Synchronization	Internal	
Sensitivity	0 Lux (IR ON)	
Back Light Compensation	AUTO	
Electronic Shutter	AUTO, Range: 1/50(1/60) ~ 1/100,000 sec.	
Gain Control	AUTO	
Lens (F2.0)	6mm	
Gamma Correction	0.45	
S/N Ratio	More than 48 dB(AGC off)	
Video Output	1 Vp-p, 75 Ohms	
Power Supply	12VDC(+/-10%)	
Power Consumption	280mA(+/-10%)	300mA(+/-10%)
Storage Temperature	-30°C ~ +60°C	
Operating Temperature	-10°C ~ +45°C	
Dimensions mm	φ84 * W115.5	
Weight	450 g	

SPECIFICATIONS ARE SUBJECT TO CHANGE WITHOUT NOTICE

Digital Surveillance System

Camera

Rear View System

Accessories

Appendix